

HIGHLY EFFICIENT SOFT MOUNTED WASHER EXTRACTORS

FX
RANGE

FX 350 **FX 450** **FX 600**

35KG 45KG 60KG
77LB 99LB 132LB



FEATURES

- Freestanding, high spin
- Patented Cascade Drum™
- Stainless steel drum and tub
- Xcontrol Plus™ - Fully programmable
- 3rd water inlet, high inlets capacity
- 2x large drain valves (Ø 76 mm)
- Easy Soap™ - liquid soaps connection
- Large door opening for easy loading unloading
- Ergonomic height of door enables easy access with trolleys
- USB and RS485 plug (on the back panel)
- User Friendly control position regardless
- Bumper (front side protection)
- Soap hopper - new sleek design

OPTIONS

- Stainless steel front
- Liquid soap pumps
- Recycle valve
- Steam heating version
- Air operated water inlets
- OPTILOAD™ - weighing system
- Water sample tap
- Extra signalization (orange light & horn)
- Isolation for energy and noise reduction
- Forward tilting (n/a for FX350)
- Trace-Tech™ - laundry management software



ERGONOMICAL
CONSTRUCTION



LARGE DOOR
OPENING



LOW WATER
AND ENERGY
CONSUMPTION



GET AHEAD IN LAUNDRY

TYPE		FX350	FX450	FX600
INNER DRUM				
capacity	kg	35	45	60
volume	litres	350	450	600
diameter	mm	914	914	1035
DRUM SPEED				
Wash speed (max)	rpm	45	45	42
Extraction speed (max)	rpm	839	839	788
G-FACTOR				
		360	360	360
HEATING				
electricity	kW	24	36	54
steam	bar	3-8	3-8	3-8
hot water	°C	90	90	90
Sound pressure level	dB (A)	<75	<75	<75
Water valves connection	BSP	1"	1"	1"
Water pressure	kPa	100-800	100-800	100-800
Rec. water pressure	kPa	300-500	300-500	300-500
Water inlet	l/min	578	578	578
Drain valve	outer Ø mm	2x76	2x76	2x76
Flow amount with drain valve	l/min			
		210	210	210
Steam valve connection	BSP	3/4"	3/4"	3/4"
Steam pressure	kPa	300-800	300-800	300-800
DIMENSIONS				
Size H×W×D	mm	1925x1315x1270	1925x1315x1502	1925x1315x1502
Net weight	kg	1010	1350	1500
TRANSPORT DATA				
Packed H×W×D	mm	2125x1425x1470	2125x1425x1700	2125x1425x1700
Gross weight	kg	1170	1490	1640

Front side

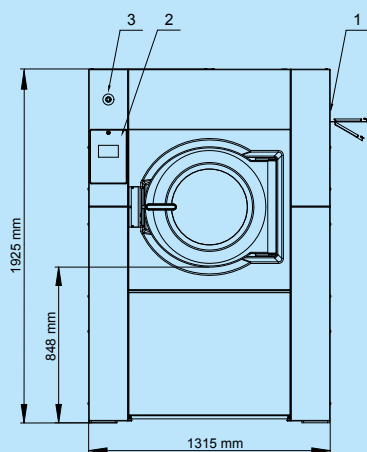

Left side

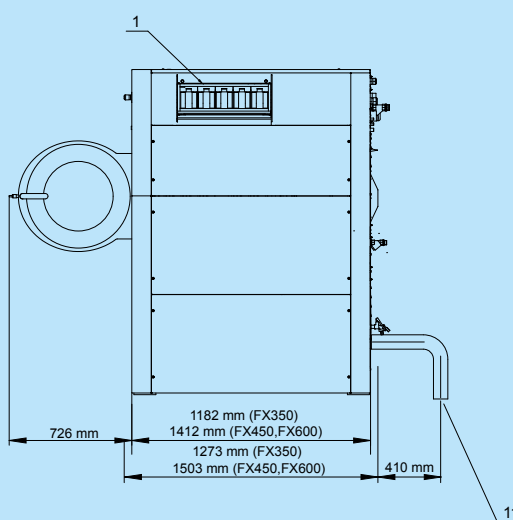

Rear side

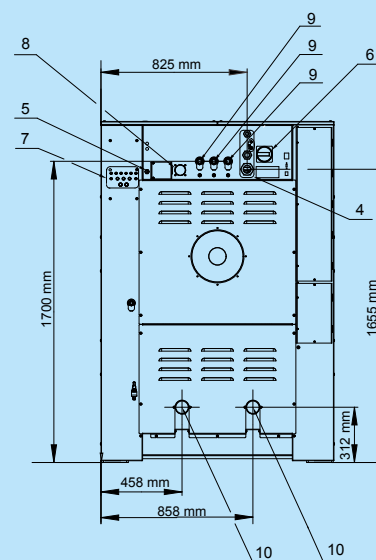

- 1 Soap hopper
- 2 Keyboard
- 3 Emergency stop
- 4 Electrical connection

- 5 Electrical connection to liquid soap
- 6 Main switch
- 7 Liquid soap pump connections

- 8 Air vent tub
- 9 Water connection
- 10 Drain valve
- 11 Water Sample Tap

The company preserves the right to change the machines and the specification in this leaflet at any time, without prior notice. Details and photographs are only for information and never binding.

www.primuslaundry.com

Primus by Alliance Laundry Systems



12-2017